



4" SIDE PORT PRESSURE VESSELS

TECHNICAL MANUAL

BEL COMPOSITE IBERICA S.L.

Parque Tecnológico Fuente Álamo. Ctra. del Estrecho-Lobosillo, km 2.

30320 Fuente Álamo, Murcia, Spain – CIF B30781215

Tel.: +34 968 197 501 | www.belvessels.com | iberica@bel-g.com

August, 2024 - Rev.6 - Page 1 of 30

INTRODUCTION

BEL, founded in 1966, specializes in the design and manufacture of a variety of products made from advanced composite materials. With over 50 years of experience, the company has developed and mastered the innovative technologies necessary to manufacture the highest quality composite products. Combining innovation, technology, responsibility and dedication, our goal is to become the leader in providing commercial and industrial composite vessels for our client's needs.

BEL pressure vessels are manufactured from filament wound fiber reinforced plastic (FRP), wound over precision mandrels, using a superior epoxy resin, which results in the ultimate combination of physical strength and an ultra-smooth inside surface. Vessels are tested according to the requirements of ASME code section X, the internationally recognized standard for pressure vessel construction.

BEL holds ISO 9001 quality systems certification, and its quality assurance is also approved for in-house final inspection by many of its customers.

The BEL family of pressure vessels is designed to be used as housings for all 4", 8", 9" and 16" inch spiral-wound Reverse Osmosis (RO), Nanofiltration (NF) and Ultra filtration (UF) membrane elements.

The pressure vessels are manufactured in different configurations, according to the required operating pressures, filtration type, and piping layout. In order to enhance interchangeability and facilitate the use and maintenance of the vessels, the utilization of identical parts and sub-assemblies has been maximized throughout the design of the vessel. For better performance and longer service life, each model is manufactured from the highest quality and highest performing materials of construction.

TABLE OF CONTENTS

1. SAFETY PRECAUTIONS.	4
2. INSTALLATION NOTES.	5
3. COMPONENT LIST.	6
3.1. BEL 4" Pressure vessel 300 psi. Multi/Side Port type.	6
3.2.- BEL 4" Pressure vessel 450 psi. Multi/Side Port type.	8
3.3.- BEL 4" Pressure vessel 600 psi. Multi/Side Port type.	10
3.4.- BEL 4" Pressure vessel 1000 psi. Multi/Side Port type.	11
3.5.- BEL 4" Pressure vessel 1200 psi. Multi/Side Port type.	12
3.6. BEL 4" Pressure vessel 1500 psi. Multi/Side Port type.	13
4. MAINTENANCE.	14
4.1.- End Cap Assembly.	14
4.1.1. Head Components BEL 4" - 300/450 psi.	14
4.1.2. Head Components BEL 4" - 600/1000/1200 psi.	14
4.1.3. Head Components BEL 4" - 1500 psi.	15
4.2. Head Assembly.	16
4.2.1.- BEL4"- 300/450 psi vessels.	16
4.2.2.- BEL4"- 600/1000/1200/1500 psi vessels.	19
4.3.- Head disassembly.	22
4.4.- Visual inspection.	24
4.5.- Loading the membrane element.	25
ANNEX 1 - BEL Puller For 4" pressure vessels heads extraction.	26
ANNEX 2 - BEL Pusher For 4" and pressure vessels heads installation.	27
ANNEX 3 - Shimming procedure.	28
ANNEX 4 - Ring replacement and scratches treatment procedure.	30

1. SAFETY PRECAUTIONS.

1.1. BEL pressure vessels are designed for high-pressure operations. Improper installation, operation service or maintenance may cause severe damage to property, physical injury or death.

1.2. BEL pressure vessels are designed for water treatment only.

1.3. Operation of a vessel outside the design limits will make void the warranty and may result in vessel fatigue with possible eventual explosive head failure. Although each vessel is tested at 110% of the design pressure **LONG-TERM OPERATION ABOVE DESIGN PRESSURE MUST BE PREVENTED**. Permeate port pressure **MUST NOT EXCEED 125 psi**. (8.6 bar). Other options are available, please, consult BEL

1.4. Vessels should **NOT BE OPERATED** at temperatures above **65° C (150°F)**.

1.5. The pressure vessel **MUST NOT BE USE AS** a support. Piping manifolds and other fittings should be properly designed system framework. **OPERATING PERSONNEL SHOULD BE DISCOURAGED FROM APPLYING UNDUE FORCE TO ANY FITTINGS CONNECTED DIRECTLY TO A PRESSURE VESSEL.**

1.6. Only **QUALIFIED MECHANICS**, with proved experienced in working with high pressure hydraulic systems, should be allowed to disassemble or assemble the vessel.

1.7. Regularly inspect the system to ensure that the various components have not deteriorated or been damaged. Replace any faulty component, make sure the reason for the fault has been found and fixed as well.

1.8. Make sure that vessels and associated pipe systems are fully depressurized before attempting any service or maintenance operation.

1.9. Be careful not to scratch the inside wall of the shell, especially at the inner sealing area near the groove.

1.10. Corroded parts may cause difficulties in removing the head or other components. Do not try to force remove components before all visible signs of corrosion have been eliminated.

1.11. Inspect end closures regularly; replace components that have deteriorated and correct causes of corrosion.

1.12. **DO NOT TOLERATE LEAKS**, or allow end closures to be routinely wetted in any way.

2. INSTALLATION NOTES.

2.1. Provide adequate room for serving at both ends of vessel. Elements are installed from the upstream end, pushed through towards the downstream end and eventually removed from the downstream end.

2.2. Make sure that the vessel is horizontally installed on support saddles. For other options, please, consult BEL.

2.3. The vessels must not be rigidly clamped in place, mounting design must allow for both radial and axial expansion (typically up to 0.5 mm radial and up to 2-3 mm axial). Restriction can result in damage to the vessel and other system components.

2.4. Straps should be tightened enough to hold the vessel onto the support pads. Using a wrench, tighten mounting bolts, but never so tightly (with torque 2-3 Nm) as to restrict expansion.

2.5. A flexible piping connection should be provided in order to prevent unwanted loads transfer from the manifolds to the permeate connection and to permit decoupling the header from the vessel.

2.6. The recommended permeate port connection is a U-bend pipe with flexible connections at each end.

2.7. The piping system must be connected to the ports using flexible connectors in order to allow relative movement of the vessels and the piping system. (Victaulic or equivalent connections are recommended).

2.8 Space must be allowed between the port faces of the pressure vessel (multiport version) or between the port face and the connecting pipe (sideport version) to avoid stress in the area of feed/rejection ports of the pressure vessels during installation. See TABLE 2.1.

Side Port	 Spacing [mm]- X	 Max Offset* [mm]	 Max Angle [Deg]
1"	2 – 0.5	2	2.2

Table 2.1

3. COMPONENT LIST.

3.1. BEL 4" Pressure vessel 300 psi. Multi/Side Port type.

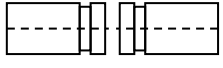
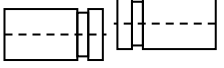
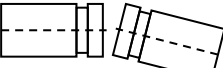
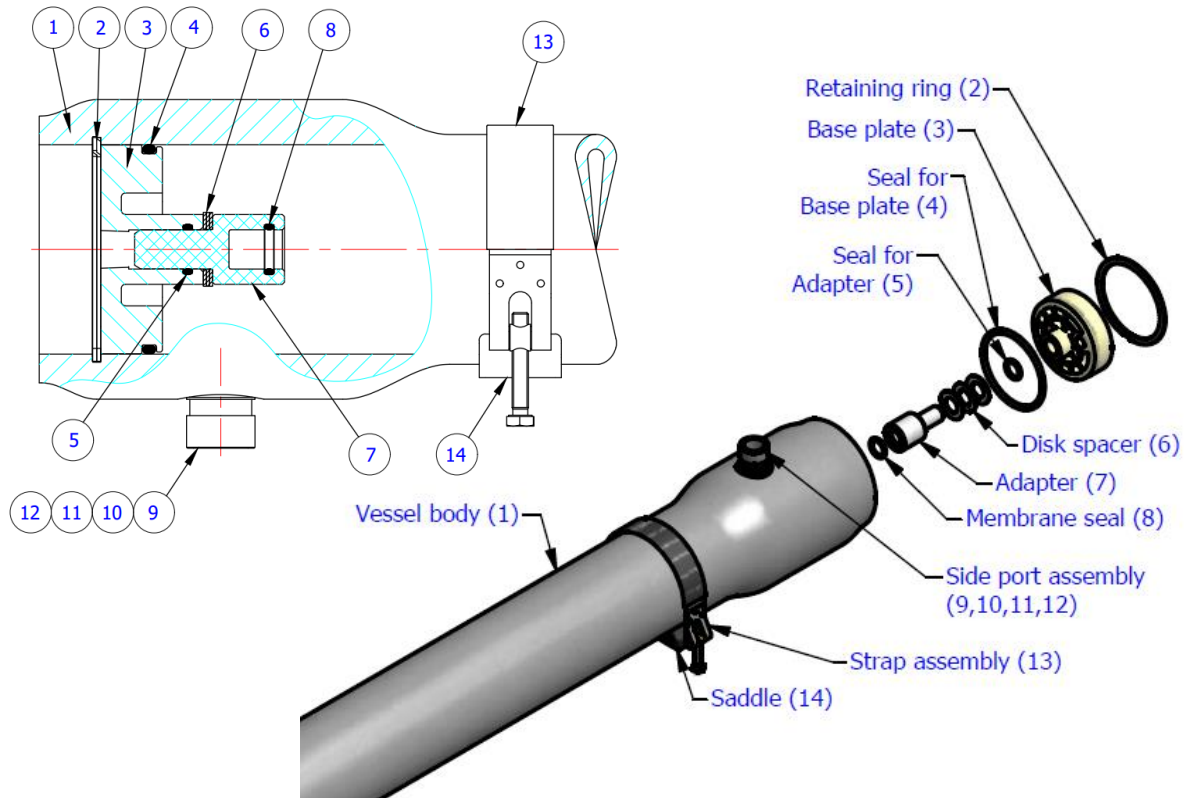

Item	Part number	Q-ty	Description	Material
1	4 / 1-2 / 300- / 0..6(12)	1	Body of Pressure vessel	Glass / Epoxy
2	55410208	2	Retaining ring	316 Stainless steel
3	003-400-0005	2	Base plate	Engineering plastic
4	55412360	2	Seal for Base plate	EPDM
5	55412377	0-6	Disk spacer	Engineering plastic
6	55412367	2	Seal for Adapter	EPDM
7	See table 3.1.2	2	Adapter for Ø 0.75"	Engineering plastic
8	55412367	2	Membrane seal for Ø 0.75"	EPDM
9	See table 3.1.1	2	Side port 1"/1.5" victaulic	316 Stainless steel
10	See table 3.1.1	2	Seal for Side port	EPDM
11	See table 3.1.1	2	Disk for Side port	316 Stainless steel
12	See table 3.1.1	4	Retaining ring	316 Stainless steel
13	55410246	2	Strap assy.	316 Stainless steel
14	55410352	2-3	Saddle	Engineering plastic

Notes:

- 1) Items 13 & 14 are optional. Delivered upon request. Priced separately.
- 2) Number of elements can vary between 1-6 for membrane length of 40", or 1-12 for membrane length of 21".
- 3) Items 5, 7 & 8 are not used in the vessels with 1 or 2 membrane elements.
- 4) Item 3 corresponds to membrane elements with permeate tube 0.75".
- 5) Items 7 & 8 can be changed to fit more types of permeate tube.

Side port Ø	Side port	Disk for side port	Seal	Retaining ring
1"	009-106-0450	006-116-1202	014-100-0505	011-100-1202
1.5"	040-156-0604	006-156-0452	014-150-0506	011-150-1202

Table 3.1.1 (Kits of sideports)

Side port Ø	Nº of membranes 40"	Part Description	Part Number
1"	1 a 2	Adapter 0.75" Female	Not used
1"	1 a 2	Adapter 0.75" Female Blind	Not used
1"	3 a 6	Adapter 0.75" Female	001-075-1200
1"	3 a 6	Adapter 0.75" Female Blind	001-075-1208
1.5"	1 a 6	Adapter 0.75" Female Long	001-075-1204
1.5"	1 a 6	Adapter 0.75" Female Long Blind	001-075-1214

Table 3.1.2 (Adapters)

3.2.- BEL 4" Pressure vessel 450 psi. Multi/Side Port type.

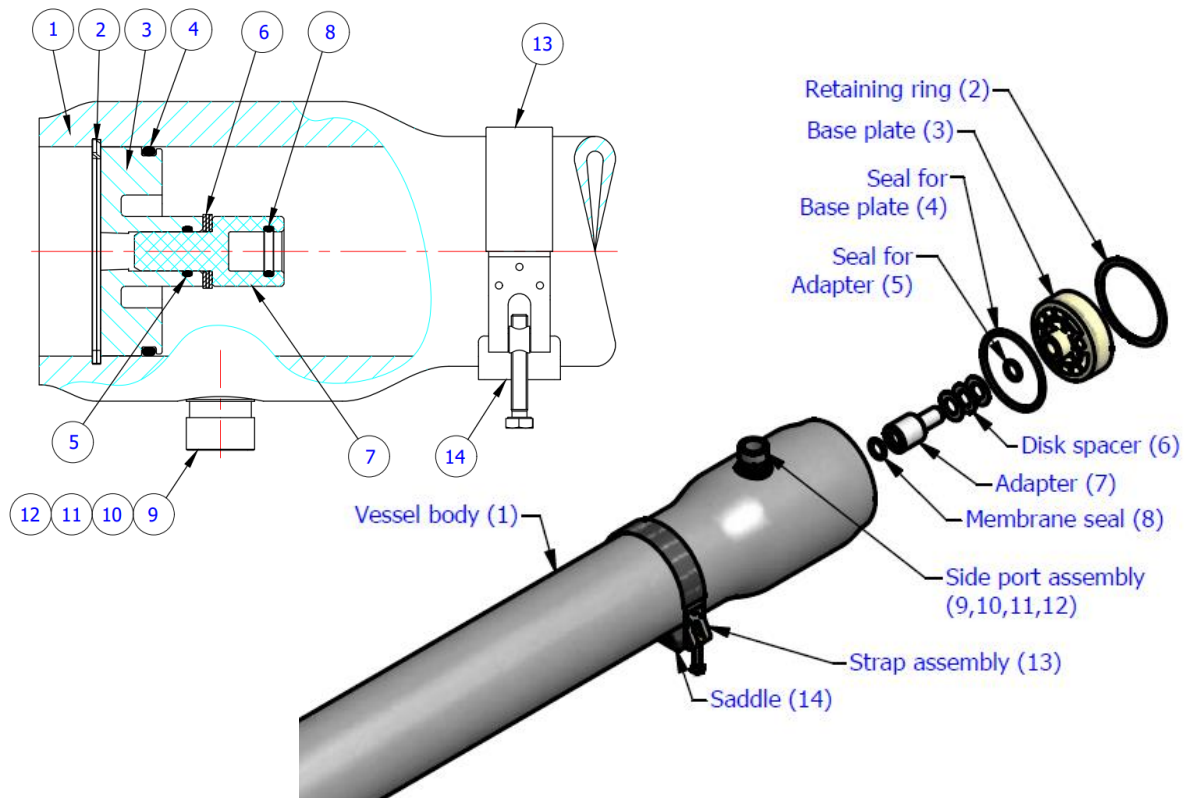

Item	Part number	Q-ty	Description	Material
1	4 / 1-2 / 450- / 0..6(12)	1	Body of Pressure vessel	Glass / Epoxy
2	55410208	2	Retaining ring	316 Stainless steel
3	003-400-0005	2	Base plate	Engineering plastic
4	55412360	2	Seal for Base plate	EPDM
5	55412377	0-6	Disk spacer	Engineering plastic
6	55412367	2	Seal for Adapter	EPDM
7	See table 3.2.2	2	Adapter for Ø 0.75"	Engineering plastic
8	55412367	2	Membrane seal for Ø 0.75"	EPDM
9	See table 3.2.1	2	Side port 1"/1.5" victaulic	316 Stainless steel
10	See table 3.2.1	2	Seal for Side port	EPDM
11	See table 3.2.1	2	Disk for Side port	316 Stainless steel
12	See table 3.2.1	4	Retaining ring	316 Stainless steel
13	55410246	2	Strap assy.	316 Stainless steel
14	55410352	2-3	Saddle	Engineering plastic

Notes:

- 1) Items 13 & 14 are optional. Delivered upon request. Priced separately.
- 2) Number of elements can vary between 1-6 for membrane length of 40", or 1-12 for membrane length of 21".
- 3) Items 5, 7 & 8 are not used in the vessels with 1 or 2 membrane elements.
- 4) Item 3 corresponds to membrane elements with permeate tube 0.75".
- 5) Items 7 & 8 can be changed to fit more types of permeate tube.

Side port Ø	Side port	Disk for side port	Seal	Retaining ring
1"	009-106-0450	006-116-1202	014-100-0505	011-100-1202
1.5"	040-156-0604	006-156-0452	014-150-0506	011-150-1202

Table 3.2.1 (Kits of sideports)

Side port Ø	Nº of membranes 40"	Part Description	Part Number
1"	1 a 2	Adapter 0.75" Female	Not used
1"	1 a 2	Adapter 0.75" Female Blind	Not used
1"	3 a 6	Adapter 0.75" Female	001-075-1200
1"	3 a 6	Adapter 0.75" Female Blind	001-075-1208
1.5"	1 a 6	Adapter 0.75" Female Long	001-075-1204
1.5"	1 a 6	Adapter 0.75" Female Long Blind	001-075-1214

Table 3.2.1 (Adapters)

3.3.- BEL 4" Pressure vessel 600 psi. Multi/Side Port type.

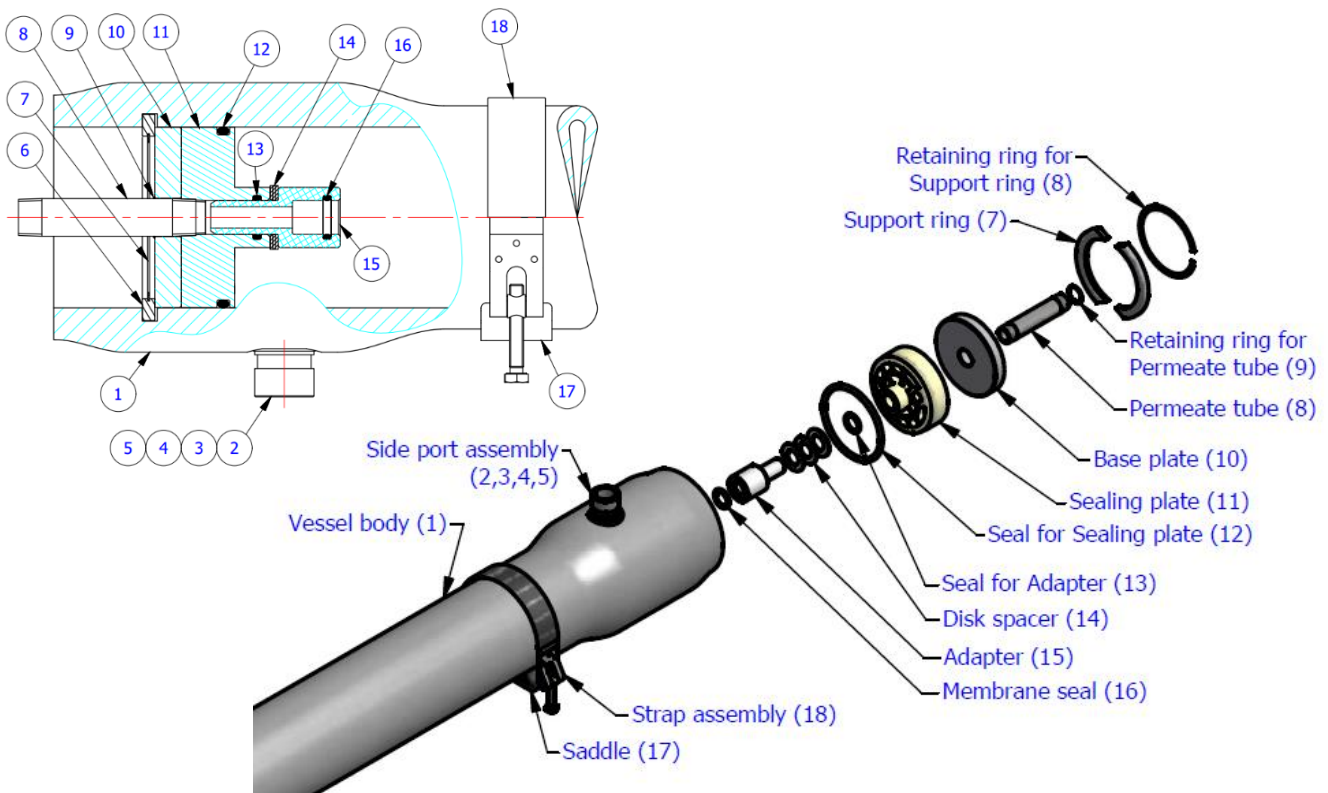

Item	Part number	Q-ty	Description	Material
1	40600-/0..6(12)	1	Body of Pressure vessel	Glass / Epoxy
2	009-106-0450	2	Side port 1" victaulic	316 Stainless steel
3	014-100-0505	2	Seal for Side port	EPDM
4	006-116-1202	2	Disk for Side port	316 Stainless steel
5	011-100-1202	4	Retaining ring	316 Stainless steel
6	005-461-1200	2	Support ring	Aluminum
7	011-401-1202	2	Retaining ring	316 Stainless steel
8	008-400-1215	2	Permeate tube	Engineering plastic
9	55412369	2	Retaining ring for P. tube	316 Stainless steel
10	003-420-1215	2	Base plate	Aluminum
11	003-400-0005	2	Sealing plate	Engineering plastic
12	55412360	2	Seal for S. plate	EPDM
13	55412367	2	Seal for Adapter	EPDM
14	55412377	0-6	Disk spacer	Engineering plastic
15	001-075-1200	2	Adapter for Ø 0.75"	Engineering plastic
16	55412367	2-4	Membrane seal for Ø 0.75"	EPDM
17	55410352	2-3	Saddle	Engineering plastic
18	55410246	2	Strap assy.	316 Stainless steel

Notes:

- 1) Items 17 & 18 are optional. Delivered upon request.
- 2) Number of elements can vary between 1-6 for membrane length of 40", or 1-12 for membrane length of 21".
- 3) Items 15 & 16 can be changed to fit more types of permeate tube.
- 4) Item 15 for permeate tube Ø 0.75", part number of Blind adapter - 001-075-1208.

BEL COMPOSITE IBERICA S.L.

Parque Tecnológico Fuente Álamo. Ctra. del Estrecho-Lobosillo, km 2.
 30320 Fuente Álamo, Murcia, Spain – CIF B30781215
 Tel.: +34 968 197 501 | www.belvessels.com | iberica@bel-g.com

3.4.- BEL 4" Pressure vessel 1000 psi. Multi/Side Port type.

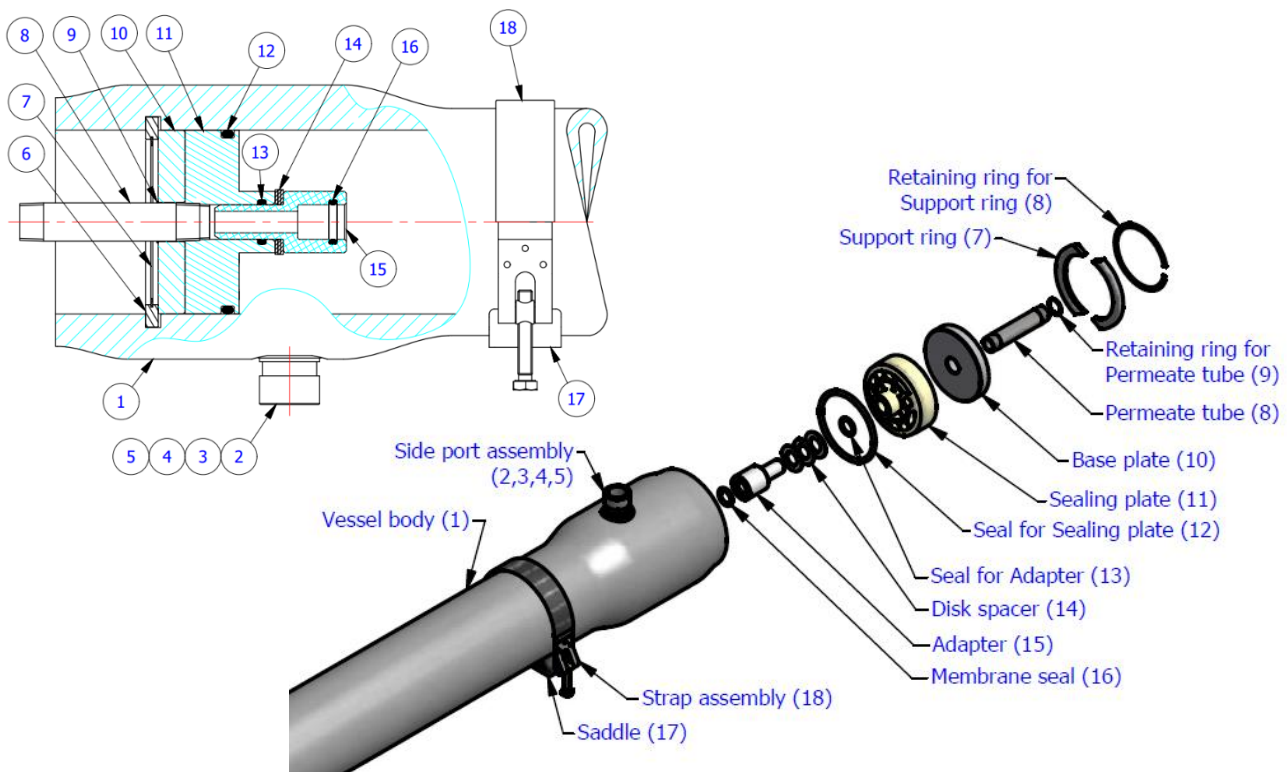

Item	Part number	Q-ty	Description	Material
1	401000-0..6(12)	1	Body of Pressure vessel	Glass / Epoxy
2	009-107-1200	2	Side port 1" victaulic	Super Duplex Stainless steel
3	014-100-0505	2	Seal for Side port	EPDM
4	006-116-1202	2	Disk for Side port	316 Stainless steel
5	011-100-1202	2	Retaining ring	316 Stainless steel
6	005-461-1200	2	Support ring	Aluminum
7	011-401-1202	2	Retaining ring	316 Stainless steel
8	008-400-1215	2	Permeate tube	Engineering plastic
9	55412369	2	Retaining ring for P. tube	316 Stainless steel
10	003-420-1215	2	Base plate	Aluminum
11	003-400-0005	2	Sealing plate	Engineering plastic
12	55412360	2	Seal for S. plate	EPDM
13	55412367	2	Seal for Adapter	EPDM
14	55412377	0-6	Disk spacer	Engineering plastic
15	001-075-1200	2	Adapter for Ø 0.75"	Engineering plastic
16	55412367	2-4	Membrane seal for Ø 0.75"	EPDM
17	55410352	2-3	Saddle	Engineering plastic
18	55410246	2	Strap assy.	316 Stainless steel

Notes:

- 1) Items 17 & 18 are optional. Delivered upon request.
- 2) Number of elements can vary between 1-6 for membrane length of 40", or 1-12 for membrane length of 21".
- 3) Items 15 & 16 can be changed to fit more types of permeate tube.
- 4) Item 15 for permeate tube Ø 0.75", part number of Blind adapter - 001-075-1208.

BEL COMPOSITE IBERICA S.L.

Parque Tecnológico Fuente Álamo. Ctra. del Estrecho-Lobosillo, km 2.
 30320 Fuente Álamo, Murcia, Spain – CIF B30781215
 Tel.: +34 968 197 501 | www.belvessels.com | iberica@bel-g.com

3.5.- BEL 4" Pressure vessel 1200 psi. Multi/Side Port type.

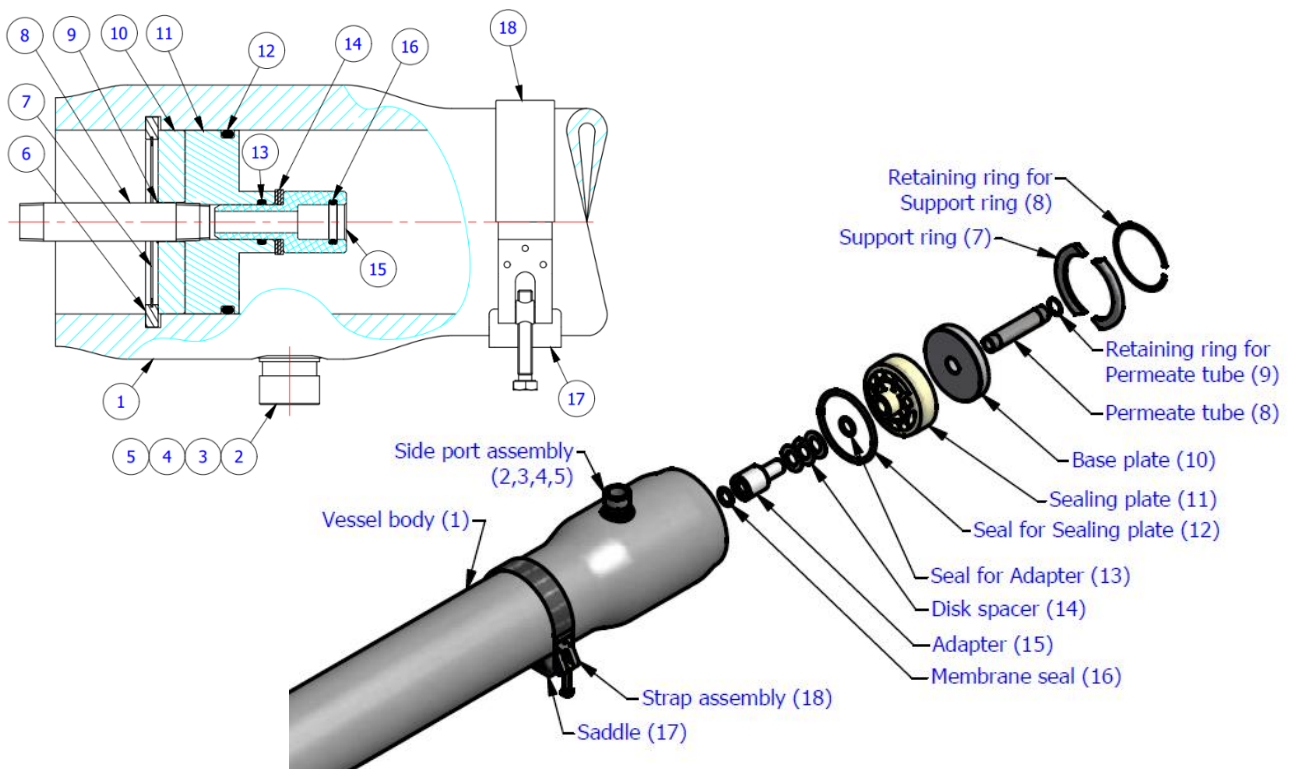

Item	Part number	Q-ty	Description	Material
1	401200-/0..6(12)	1	Body of Pressure vessel	Glass / Epoxy
2	009-107-1200	2	Side port 1" victaulic	Super Duplex Stainless steel
3	014-100-0505	2	Seal for Side port	EPDM
4	006-116-1202	2	Disk for Side port	316 Stainless steel
5	011-100-1202	2	Retaining ring	316 Stainless steel
6	005-461-1200	2	Support ring	Aluminum
7	011-401-1202	2	Retaining ring	316 Stainless steel
8	008-400-1215	2	Permeate tube	Engineering plastic
9	55412369	2	Retaining ring for P. tube	316 Stainless steel
10	003-420-1215	2	Base plate	Aluminum
11	003-400-0005	2	Sealing plate	Engineering plastic
12	55412360	2	Seal for S. plate	EPDM
13	55412367	2	Seal for Adapter	EPDM
14	55412377	0-6	Disk spacer	Engineering plastic
15	001-075-1200	2	Adapter for Ø 0.75"	Engineering plastic
16	55412367	2-4	Membrane seal for Ø 0.75"	EPDM
17	55410352	2-3	Saddle	Engineering plastic
18	55410246	2	Strap assy.	316 Stainless steel

Notes:

- 1) Items 17 & 18 are optional. Delivered upon request.
- 2) Number of elements can vary between 1-6 for membrane length of 40", or 1-12 for membrane length of 21".
- 3) Items 15 & 16 can be changed to fit more types of permeate tube.
- 4) Item 15 for permeate tube Ø 0.75", part number of Blind adapter - 001-075-1208.

BEL COMPOSITE IBERICA S.L.

Parque Tecnológico Fuente Álamo. Ctra. del Estrecho-Lobosillo, km 2.
30320 Fuente Álamo, Murcia, Spain – CIF B30781215
Tel.: +34 968 197 501 | www.belvessels.com | iberica@bel-g.com

3.6. BEL 4" Pressure vessel 1500 psi. Multi/Side Port type.

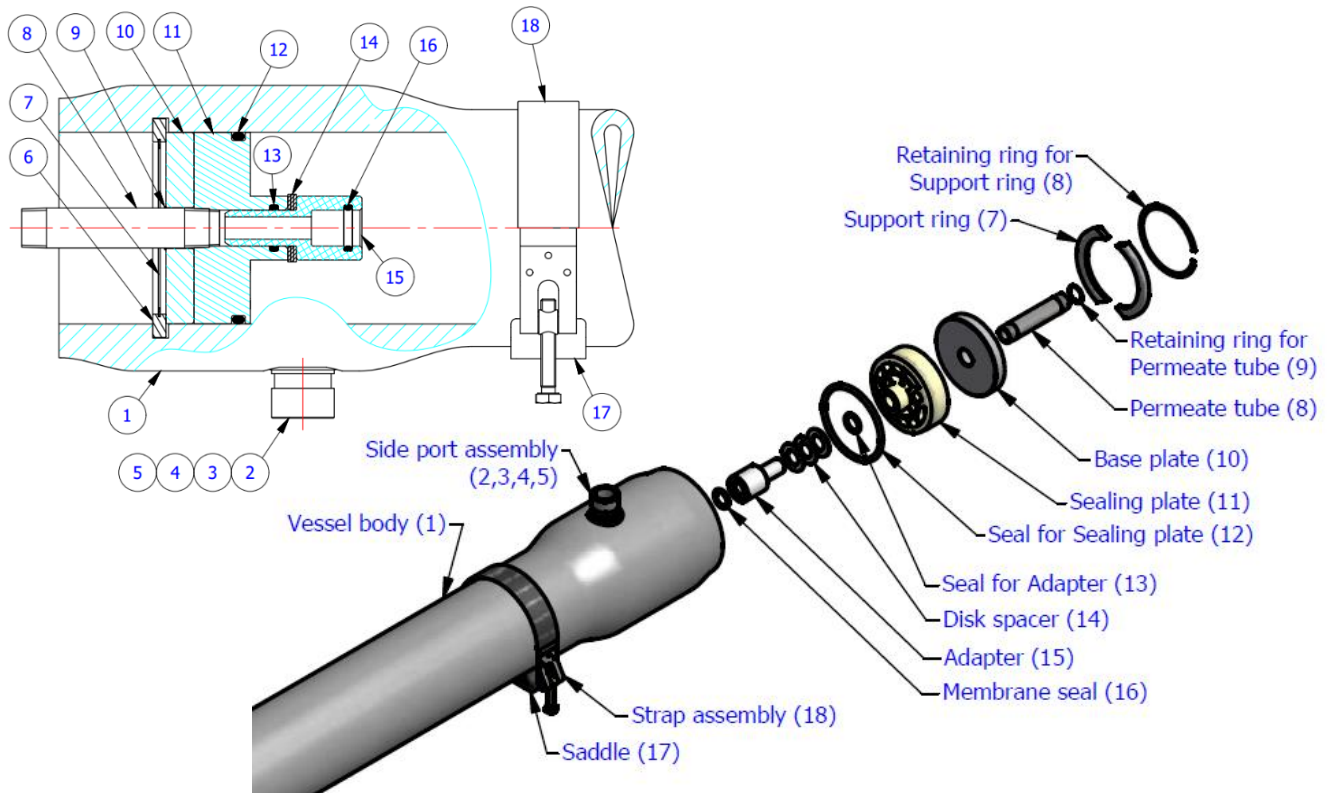

Item	Part number	Q-ty	Description	Material
1	411500-/0..6(12)	1	Body of Pressure vessel	Glass / Epoxy
2	009-107-1500	2	Side port 1" victaulic	Super Duplex Stainless steel
3	014-100-0505	2	Seal for Side port	EPDM
4	006-116-1504	2	Disk for Side port	316 Stainless steel
5	011-100-1203	2	Retaining ring	316 Stainless steel
6	005-416-1500	2	Support ring	316 Stainless steel
7	011-401-1202	2	Retaining ring	316 Stainless steel
8	008-400-1215	2	Permeate tube	Engineering plastic
9	55412369	2	Retaining ring for P. tube	316 Stainless steel
10	003-423-1215	2	Base plate	316 Stainless steel
11	003-400-0005	2	Sealing plate	Engineering plastic
12	55412360	2	Seal for S. plate	EPDM
13	55412367	2	Seal for Adapter	EPDM
14	55412377	0-6	Disk spacer	Engineering plastic
15	001-075-1200	2	Adapter for Ø 0.75"	Engineering plastic
16	55412367	2-4	Membrane seal for Ø 0.75"	EPDM
17	55410352	2-3	Saddle	Engineering plastic
18	55410246	2	Strap assy.	316 Stainless steel

Notes:

- 1) Items 17 & 18 are optional. Delivered upon request.
- 2) Number of elements can vary between 1-6 for membrane length of 40", or 1-12 for membrane length of 21".
- 3) Items 15 & 16 can be changed to fit more types of permeate tube.
- 4) Item 15 for permeate tube Ø 0.75", part number of Blind adapter - 001-075-1208.

BEL COMPOSITE IBERICA S.L.

Parque Tecnológico Fuente Álamo. Ctra. del Estrecho-Lobosillo, km 2.
30320 Fuente Álamo, Murcia, Spain – CIF B30781215
Tel.: +34 968 197 501 | www.belvessels.com | iberica@bel-g.com

4. MAINTENANCE.

4.1.- End Cap Assembly.

4.1.1. Head Components BEL 4" - 300/450 psi.



Fig. 4.1.1

4.1.2. Head Components BEL 4" - 600/1000/1200 psi.

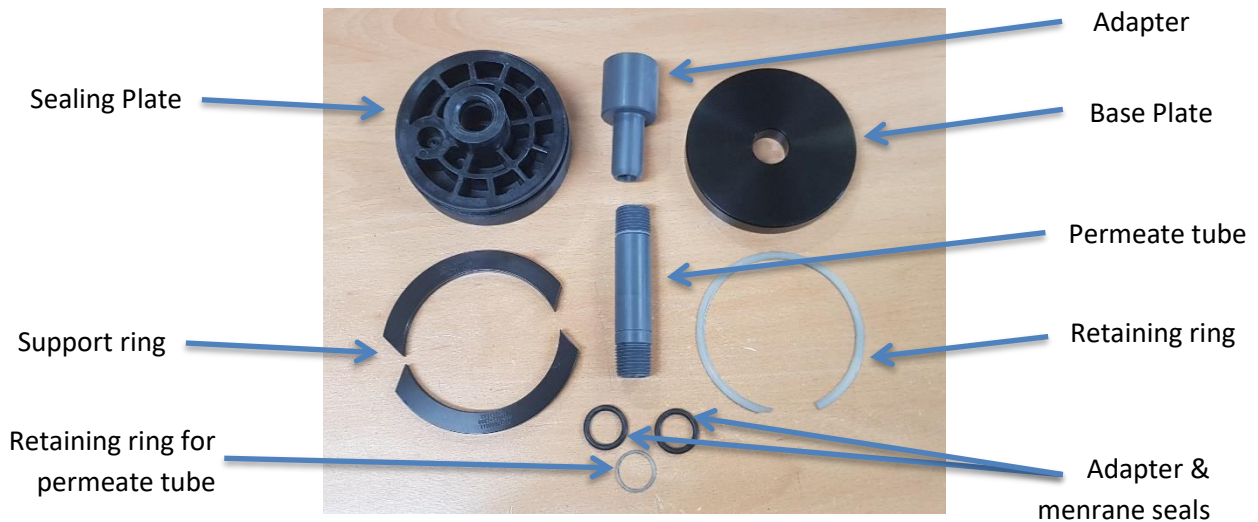

Fig. 4.1.2

4.1.3. Head Components BEL 4" - 1500 psi.

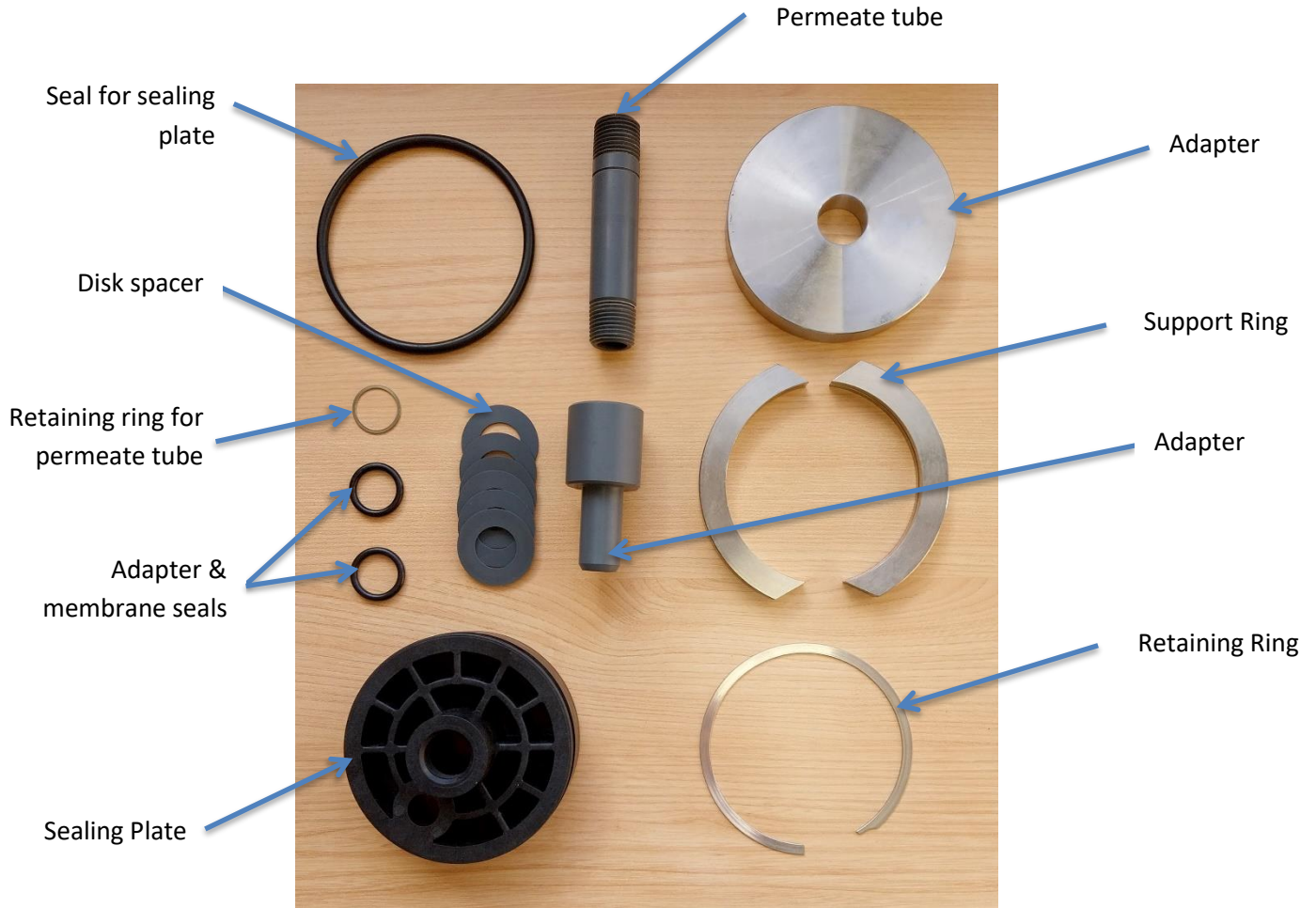

Fig. 4.1.3

4.2. Head Assembly.

4.2.1.- BEL4"- 300/450 psi vessels.

4.2.1.1. Place the seal for sealing plate in the sealing plate and apply a layer of lubricant (Glycerin, Molykote 111 or equivalent). **In head disassembly is recommended change all the seals.**

4.2.1.2. Place the seal for adapter in the adapter and apply a layer of lubricant. Do the same for the sealing plate.

4.2.1.3. Insert the adapter in the sealing plate. (Spacer disk may be required– See Annex 3).

4.2.1.4. Clean the groove area inside the pressure vessel with a dry cloth and apply a layer of lubricant.

4.2.1.5. Place the sealing plate-adapter in the groove as shown in the picture.

4.2.1.6. Insert the retaining ring in the groove.



Fig. 4.2.1.6a

BEL COMPOSITE IBERICA S.L.

Parque Tecnológico Fuente Álamo. Ctra. del Estrecho-Lobosillo, km 2.
30320 Fuente Álamo, Murcia, Spain – CIF B30781215
Tel.: +34 968 197 501 | www.belvessels.com | iberica@bel-g.com

August, 2024 - Rev.6 - Page 16 of



Fig. 4.2.1.6b

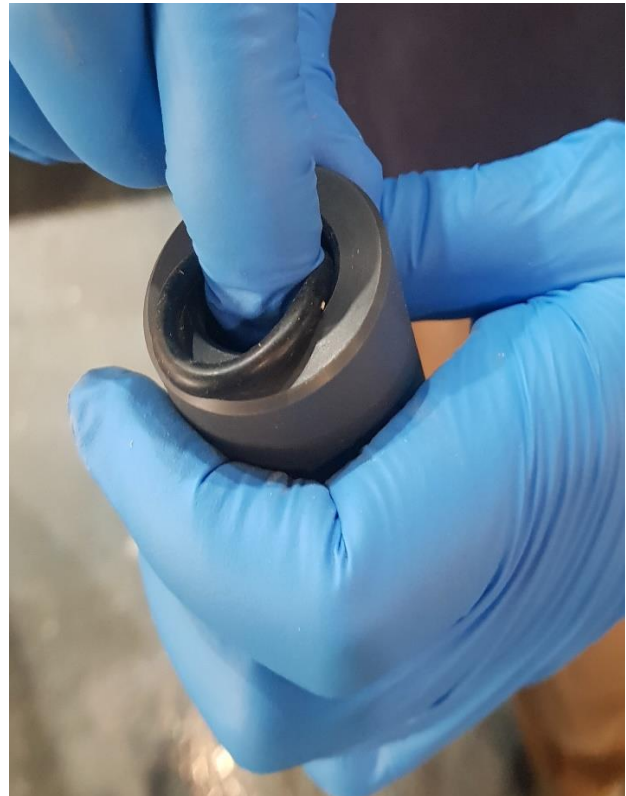

Fig. 4.2.1.6c



Fig. 4.2.1.6d

BEL COMPOSITE IBERICA S.L.

Parque Tecnológico Fuente Álamo. Ctra. del Estrecho-Lobosillo, km 2.
30320 Fuente Álamo, Murcia, Spain – CIF B30781215
Tel.: +34 968 197 501 | www.belvessels.com | iberica@bel-g.com



4.2.1.6e



4.2.1.6f



4.2.1.6g

4.2.2.- BEL4"- 600/1000/1200/1500 psi vessels.

4.2.2.1. Place the retaining ring for permeate tube in the permeate tube.

4.2.2.2. Apply PTFE at the end of the permeate tube.

4.2.2.3. Insert the permeate tube to the base plate-sealing plate set.

4.2.2.4. Place the seal for adapter in the adapter and apply a layer of lubricant. Do the same for the sealing plate.

4.2.2.5. Place the seal for sealing plate in the sealing plate and apply a layer of lubricant (Glycerin, Molykote 111 or equivalent). **Each head disassembly, change all the seals is recommended.**

4.2.2.6. Insert the adapter to the base plate-sealing plate set. (Spacer disk may be required— See Annex 3).

4.2.2.7. Clean the groove area inside the pressure vessel with a dry cloth and apply a layer of lubricant.

4.2.2.8. Place the base plate-sealing plate-adapter-permeate tube in the groove as shown in the picture.

4.2.2.9. Place the support ring in the groove.

4.2.2.10. Place the retaining ring as shown in the picture.



Fig. 4.2.2.10a



Fig. 4.2.2.10b



Fig. 4.2.2.10c



Fig. 4.2.2.10d



Fig. 4.2.2.10e



Fig. 4.2.2.10f



Fig. 4.2.2.10g



Fig. 4.2.2.10h



Fig. 4.2.2.10i



Fig. 4.2.2.10j

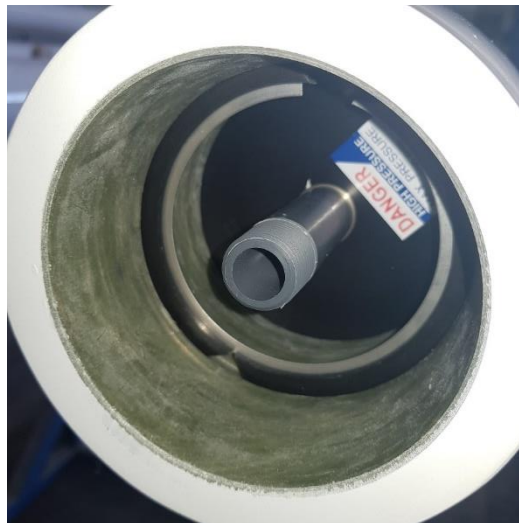

Fig. 4.2.2.10k

4.3.- Head disassembly.

4.3.1. **Relieve the pressure** - Stop all pumps and relieve pressure.

4.3.2. Disconnect all pipes from ports connecting vessel's heads.

4.3.3. Open the End Cap.

300/450 psi vessels – Use a flat-end screwdriver. Insert the blade underneath the tab of the spiral retaining ring locker and pull out the end of the spiral. Pull the spiral's end towards the center of the head and outwards until the whole length of the spiral retaining ring has been extracted.



600/1000/1200/1500 psi vessels – Use a flat-end screwdriver. Insert the blade underneath the tab of the spiral-retaining ring, lift it up and pull it out of the groove, by running your screwdriver behind the retaining ring as it continues to exit the groove, as shown in pictures. Once the retaining ring is out, remove the two locker segments from the groove.

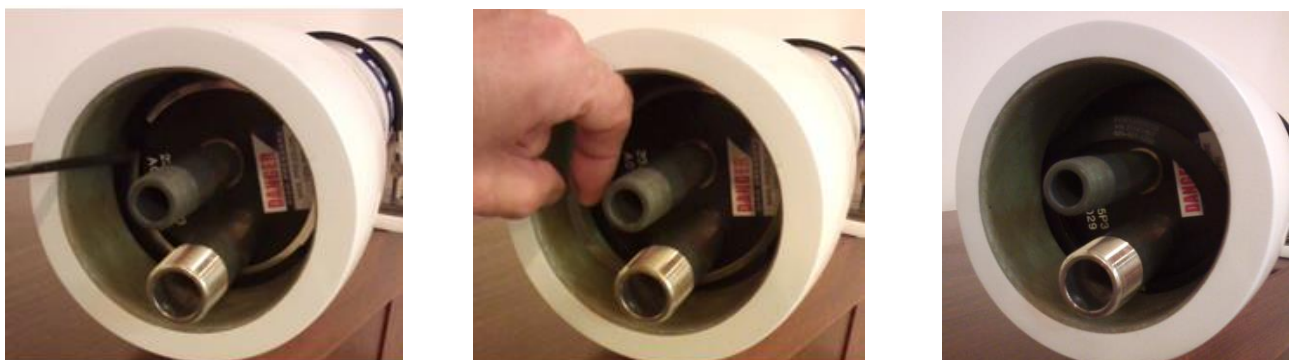

4.3.4. Head extraction.

a) Tight the puller legs (see annex 1) to the vessel wall as shown in Fig 4.3.4a to support the puller to the vessel.

Fig. 4.3.4a

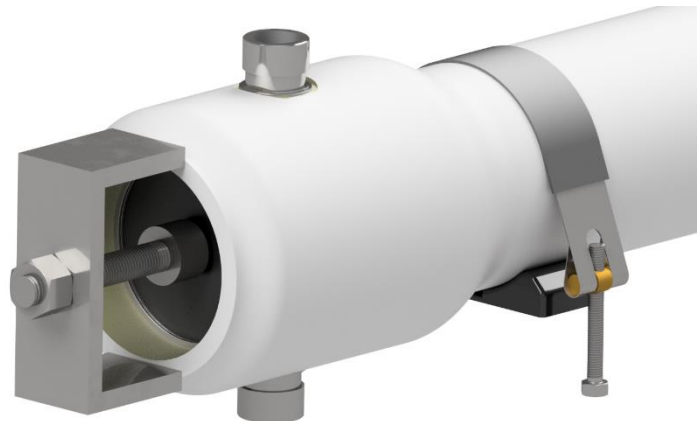

b) Screw in fully the cup to the Permeate port (clockwise) while supporting the back side of the puller.

c) Screw out the Puller's hex nut (clockwise) until the Head assembly is extracted, after that pull out the Puller with the Head assembly. As shown in Fig 4.3.4b

Fig. 4.3.4b



4.4.- Visual inspection.

Once the vessel has been opened, perform a visual inspection of the vessel, head and fittings, to locate any signs of corrosion or salt concentrations if corrosion or salt concentrations are found, follow the following steps:

Component inspection

4.4.1 Use a small wire brush to loosen any large deposits.

4.4.2 Place components in a shallow container of soapy water and scrub their surfaces with medium-grade Scotch-Brite until all corrosion is removed.

4.4.3 Rinse components with clear water.

4.4.4 Blow components dry with compressed air.

4.4.5 Examine components for damage that may affect structural strength or sealing properties.

Vessel inspection

4.4.6 If any case of deposit of foreign material has been discovered scrub surface with a fine Scotch-Brite and a mild detergent solution, clean both ends of the vessel, up to 30 cm into the vessel for 300/450 psi & 45 cm for 600/1000/1200/1500 psi.

4.4.7 If during inspection scratches are found on the inner surface of the vessel, grind the area carefully with sand paper until it is smooth.

Note! DO NOT strike or apply excessive force on the ports to remove the vessel's head.

Note! if the vessel was in service for a long time, it may be more difficult to remove the head assembly.

4.5.- Loading the membrane element.

4.5.1 Flush the vessel with fresh water to remove dust and debris.

4.5.2 Insert Head assembly, **without the O-ring** into the downstream end of the vessel.

4.5.3 Install the segments of the support ring into the locking groove.

4.5.4 Inspect the membrane element surface to find any imperfections that could scratch the vessel bore element loading. If a defect is found, which cannot be easily corrected contact the element manufacturer.

4.5.5 Apply a thin layer of lubricant to lubricate the inside of the vessel near the groove. **This will assist membrane element loading and reduce the risk of inadvertently scratching the vessel bore.**

4.5.6 Install the brine seal on the upstream end of the membrane element so that the seal's open side faces upstream (if it is not already installed by the manufacturer). Apply a thin layer of lubricant on the seal.

4.5.7 Load the first element into the upstream of the vessel. Leave 10 cm of the element projecting out of the vessel to facilitate connection with the next element.

4.5.8 Apply a small amount of lubricant (see 4.2) onto the O-ring of the interconnector and connect the interconnector to the projected end of the loaded element.

4.5.9 Line up the next element and assemble it to the inter connector which is already on the first element. **Carefully maintain element alignment during assembly, misalignment may result damage to the membrane and vessel parts.**

4.5.10 Carefully push the two elements into the vessel until the second element is projecting from the vessel approximately 10 cm. Repeat the above steps until all membrane elements have been assembled.

4.5.11 Calculate the correct shimming distance (see Annex 3) in order to avoid impact damage on the membrane and head parts during pressure drop.

4.5.12 Insert the shimming spacers on the upstream head assembly (Membrane adapter) so that the sum of their lengths will be equal to the shimming distance.

4.5.13 Install the upstream head assembly as described in section 4.2.

4.5.14 Remove the downstream head assembly and reassemble it with the O-ring.

ANNEX 1 - BEL Puller For 4" pressure vessels heads extraction.

This tool designated to extract BEL head assembly for 4" pressure vessels.

Before opening, any of the vessel's parts ensure internal pressure has been unloaded.

Note:

It is highly recommended to replace all seals each time the head is reassembled.
A seal replacement kit is available from **BEL's** Customer Service.

Part number: 069-040-1200 –for vessels 600/1000/1200/1500 psi,
069-040-0450 – for vessels 300/450 psi.

Kit assembly: Tool must be assembled as shown on illustration 1.

Figure 1 –Puller assembly

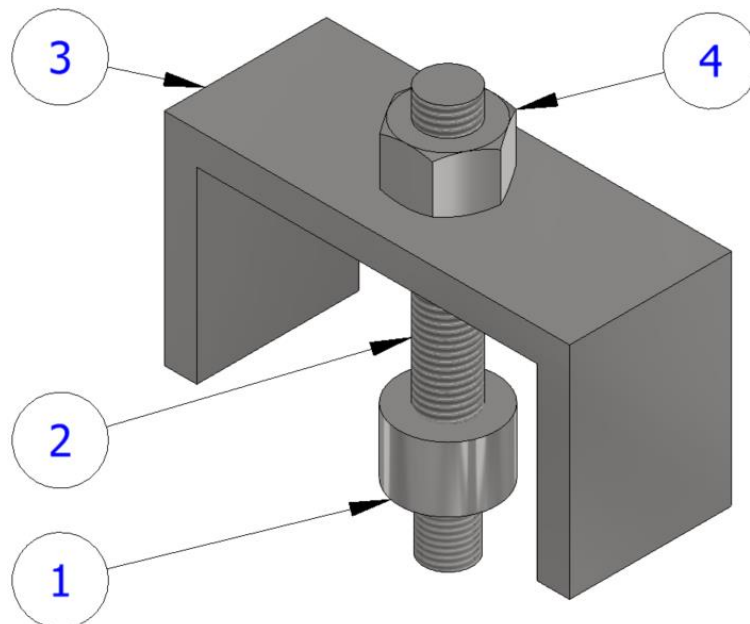

(1) Puller adapter, (2) Threaded Rod (3) Puller base, (4) Hex Nut

ANNEX 2 - BEL Pusher For 4" and pressure vessels heads installation.

This tool designated to install BEL head assembly for 4" and pressure vessels.

Note:

It is highly recommended to replace all seals each time the head is reassembled.
A seal replacement kit is available from **BEL's** Customer Service.

For Head installation apply full and reach layer of lubricant on seals, vessel's groove and vessel's sealing area.

Part number: n/a – can be used Plastic (PVC, PP) pipe for head installation.

Pipe dimensions: O.D.= 100 mm., I.D.=80 mm., Length=150 mm.

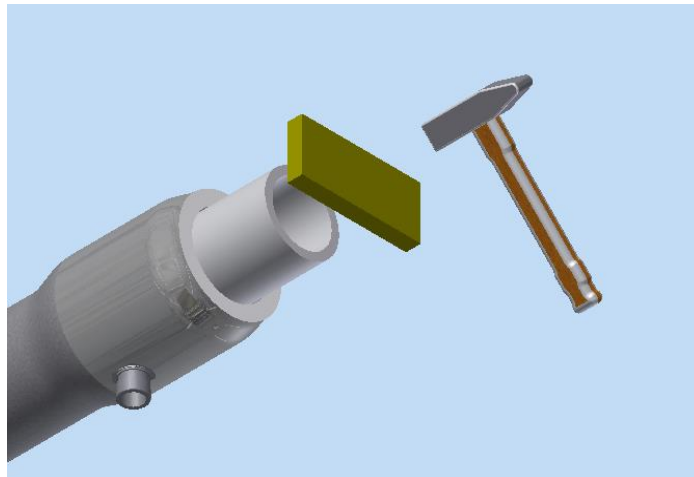

ANNEX 3 - Shimming procedure.

Correct shimming is needed in order to keep minimum Adapters and Membrane elements movement at operation time, **shimming should be applied at the feed side only**.

First, make sure the membranes is fully pressed towards the brine side. Load the head assembly and the membranes. In order to check that the membrane is fully pressed against the brine side, pull out the head assembly and measure the distance between the membrane and the locker (See "Y" in the drawing below).

This distance is equal to the total length of the head assembly - 87 mm for 300/450 psi vessels or 135 mm for 600/1000/1200 psi vessels. It is important to mention that measuring of "Y" is an option and it's not mandatory. However, it is very important* to make sure that the membrane is fully pressed before applying the shimming procedure.

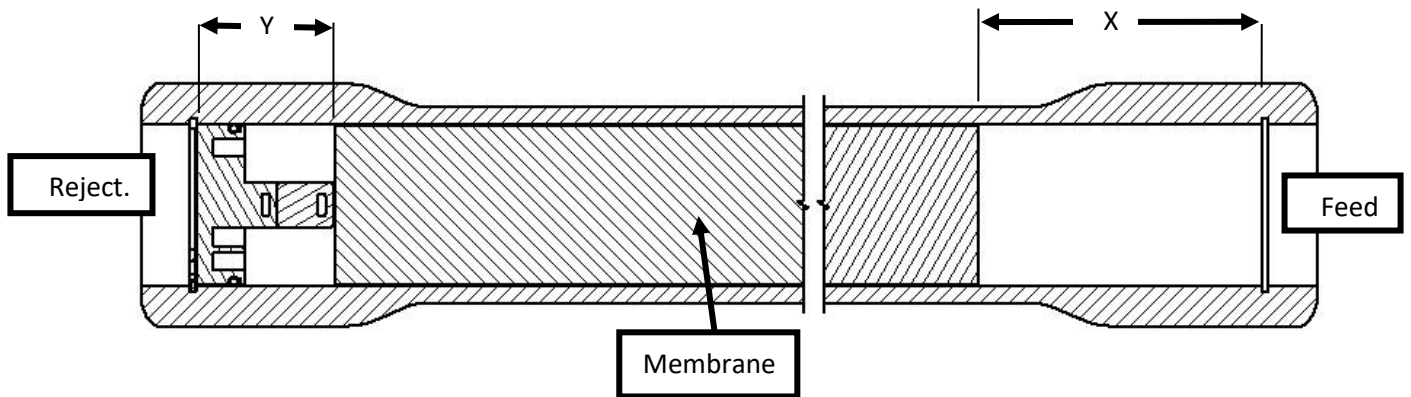

* **Note: this process is highly recommended for vessels containing 3 membranes and above.**

Correct shimming can be achieved by using the following formulas:

For BEL 4" 300/450 psi:

Let X (see drawing above) be the distance between the groove and the membrane on the feed side. Measure this distance by using a caliber between the inner side of the locker and membrane.

$$Shimming = X - t_{base\ plate} - t_{adapter} - 2 = X - 50 - 35 - 2 \Rightarrow X - 87 [mm]$$

$t_{base\ plate}$ - Thickness of base plate

$t_{adapter}$ - Thickness of adapter

For BEL 4" 600/1000/1200/1500 psi

Let X (see drawing above) be the distance between the inner side of the locker and the membrane on feed side.

$$\text{Shimming} = X - t_{\text{sealing plate}} - t_{\text{base plate}} - t_{\text{adapter}} - 2 = X - 50 - 15 - 35 - 2 \Rightarrow X - 102 \text{ [mm]}$$

$t_{\text{sealing plate}}$ - Thickness of sealing plate

$t_{\text{base plate}}$ - Thickness of base plate

t_{adapter} - Thickness of adapter

After installing the shimming, a space of 1 mm to install the retaining ring locker / locker shall remain. In case of extra space or too little space, remove or add spacers respectively until receiving a satisfying result.

ANNEX 4 - Ring replacement and scratches treatment procedure.

1. Preparations

Please, prepare the following items before proceeding:

1.1.- New intact O-Ring seal, suitable with Base/Sealing Plate type. Ensure O-Ring groove is clean and free of scratches.

1.2.- Clean cloth.

1.3.- Lubricant.

1.4.- BEL Pusher/Puller (optional).

2. O-Ring Replacement procedure

2.1.- Clean vessel internal surface at sealing area (O-Ring area) with clean damp cloth after the disassembling of the head assembly from the vessel.

2.2.- Ensure vessel sealing area is smooth and free of scratches. See next procedure for scratch treating.

2.3.- Assemble Head parts (e.g. Base Plate, Sealing Plate, Permeate Port, Adapter, O-Rings and Shims) and apply full and reach layer of lubricant on seals, vessel's groove and vessel's sealing area.

2.4.- Install Head using BEL's pusher.

3. Scratches treatment procedure

3.1.- Clean vessel internal surface at sealing area (O-Ring area) with clean damp cloth.

3.2.- Locate the scratch at the O-Ring sealing area. Scratches out of this area will not cause leaks, therefore will not be treated.

3.3.- Grind out the scratch using Extra-Fine sand paper (P400) until scratch is flat and smooth. DO NOT grind deep into the vessel, this might cause permanent damage to the vessel.

Note: In case of deep scratches or layers de-lamination please consult BEL engineering department.